

ROAD SECTION A

SELECTIVE SECTION

ROAD SECTION B

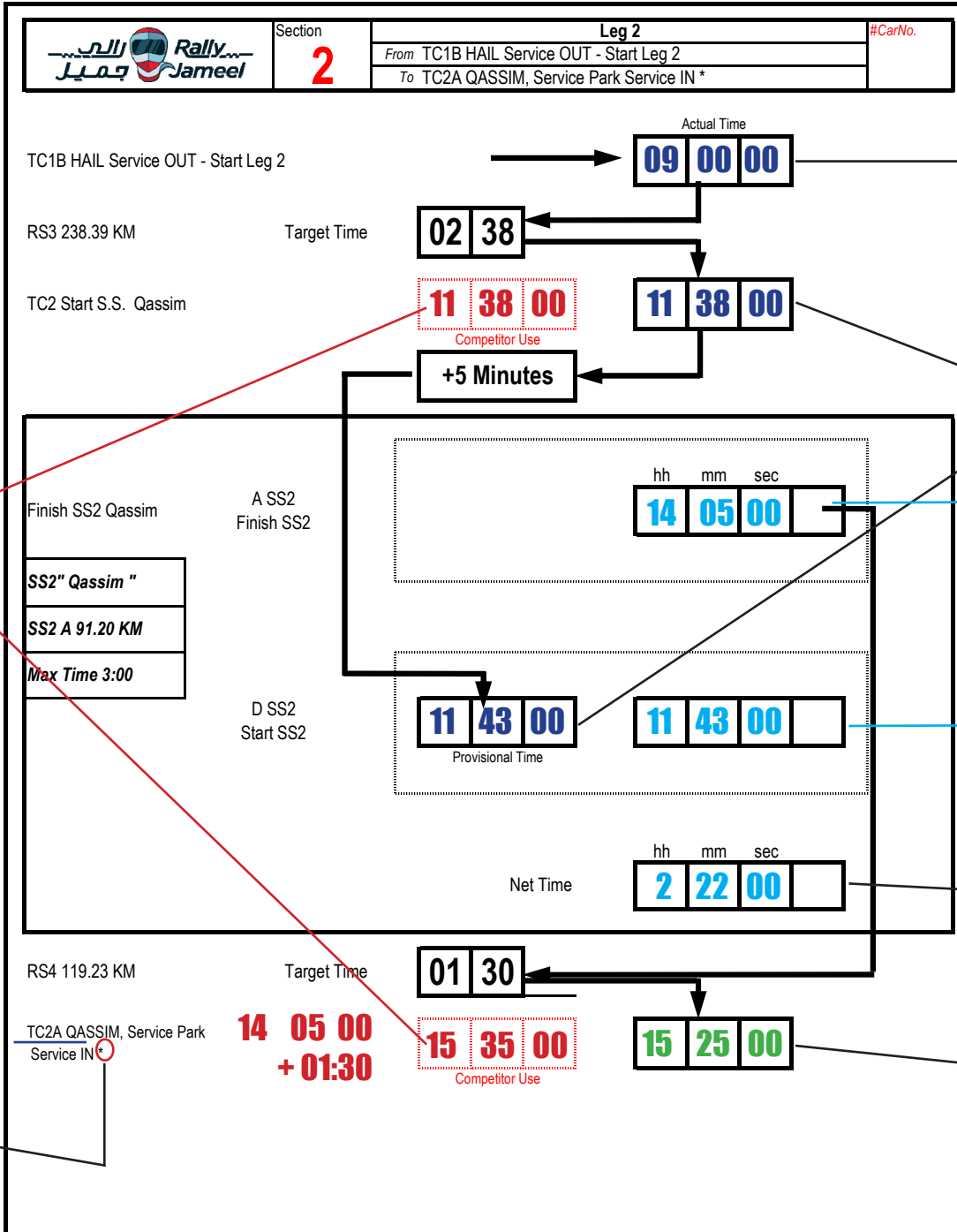

START FROM BIVOUAC
HH:MM:SS

FILL BY SAME
MARSHAL

ACTUAL FINISH TIME
FILL BY STOP MARSAL
AT ASS

ACTUAL START TIME
FILL BY START
MARSHAL AT DSS

14 05 00

-11 43 00

= 2 22 00

Finish time
Start time

ACTUAL ARRIVAL
TIME AT BIVOUAC
FILL BY SERVICE
PARK MARSHAL

TO BE FILL BY
THE COMPETITORS
(OPTIONAL)

* MEANS THAT YOU
CAN ARRIVE EARLIER
AT SERVICE PARK